

Box truss

Heavy-duty truss 30 x 20.5 spigoted

- › Heavy-duty truss 30 x 20.5 spigoted
- › Standard lengths are 10', 8' and 5'
- › Custom lengths available upon request
- › Equipped with steel spigots
- › Main chords are 2" OD x 3/16" aluminum
- › Diagonals are 1-1/2" OD x 1/8" aluminum
- › Available with casters
- › Fabricated by AWS / SFL certified welders

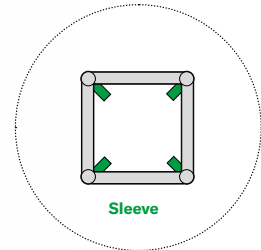

Plan Views - Connector Orientation Specified by Customer

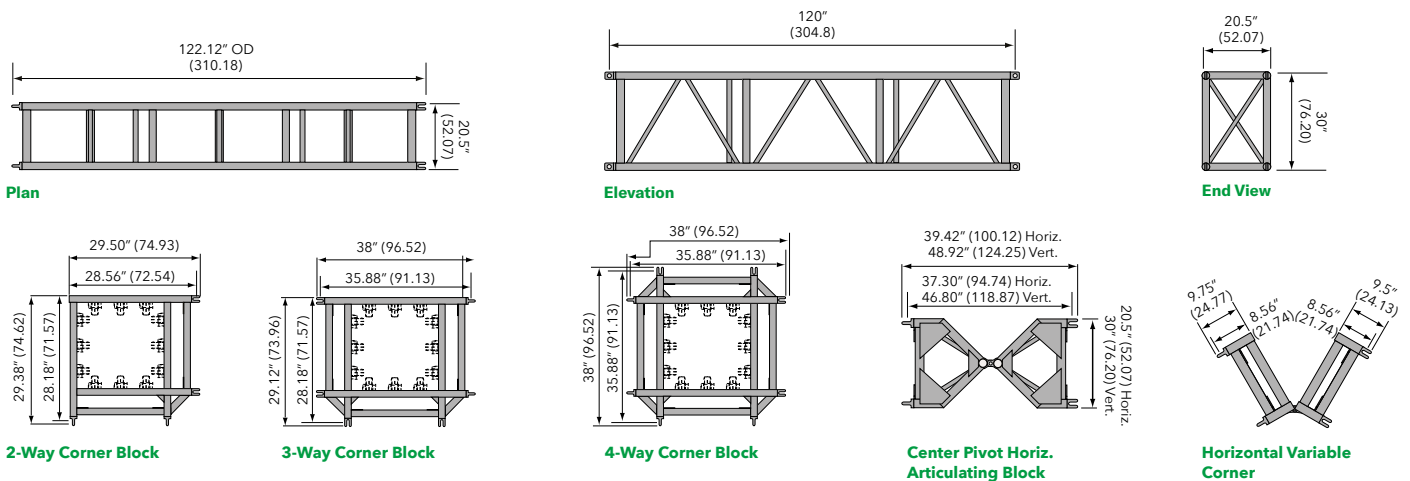

Loading chart

Span feet (meters)	Maximum allowable uniform loads			Maximum allowable point loads					
	Load lbs/ft	Load lbs (kgs)	Max Defl. in.	center point		third point		quarter point	
				Load lbs (kgs)	Max Defl. in.	Load lbs (kgs)	Max Defl. in.	Load lbs (kgs)	Max Defl. in.
10 (3.05)	3555	35550 (16125)	0.09	17780 (8065)	0.08	13330 (6046)	0.10	8888 (4032)	0.09
20 (6.09)	877	17540 (7956)	0.38	8775 (3980)	0.30	6581 (2985)	0.39	4388 (1990)	0.36
30 (9.14)	381	11430 (5185)	0.85	5725 (2597)	0.69	4294 (1948)	0.87	2863 (1299)	0.81
40 (12.19)	208	8320 (3774)	1.52	4163 (1888)	1.23	3122 (1416)	1.55	2081 (944)	1.45
50 (15.24)	127	6350 (2880)	2.36	3195 (1449)	1.95	2396 (1087)	2.42	1598 (725)	2.27
60 (18.29)	79	4710 (2136)	3.22	2356 (1069)	2.67	1767 (802)	3.28	1178 (534)	3.10

5/8" diameter Grade 8 Bolts with standard washers through 3/8" gusset plates

Note: Deflections reported in the tables on the left are the maximum expected for full loadings (indoor only). All loads are based on 10' (3.05 m) sections. Other section lengths are available. Load tables are reprinted from engineering reports developed by Parkhill, Smith & Cooper, Inc., Structural Engineers, and apply to truss fabricated after December 1989.

Heavy-duty truss 30 x 20.5 spigoted Connections are steel spigots & 3/4" clevis pins

Product Description	Item Code	Weight lbs (kgs)
5 FT HEAVY-DUTY TRUSS	TC 3020-060S	90 (41)
8 FT HEAVY-DUTY TRUSS	TC 3020-096S	120 (55)
10 FT HEAVY-DUTY TRUSS	TC 3020-120S	132 (60)
HEAVY-DUTY 2-WAY CORNER	TC 3020-CS2	77 (35)
HEAVY-DUTY 3-WAY CORNER	TC 3020-C3S	95 (43)
HEAVY-DUTY 4-WAY CORNER	TC 3020-C4S	121 (55)
HD ARTICULATING BLOCK HORIZONTAL (center pivot)	TC 3020-AHS	91 (42)
HD ARTICULATING BLOCK VERTICAL (center pivot)	TC 3020-AVS	92 (42)
HD VARIABLE CORNER HORIZONTAL (book style with brace)	TC 3020-VHS	72 (33)
HD VARIABLE CORNER VERTICAL (book style with brace)	TC 3020-VVS	68 (31)
HD 2-WAY SLEEVE FOR 12" TOWER*	TC 3020-S2S	97 (44)
HD 3-WAY SLEEVE FOR 12" TOWER*	TC 3020-S3S	115 (53)
HD 4-WAY SLEEVE FOR 12" TOWER*	TC 3020-S4S	141 (64)
3/4" CLEVIS PIN	TC CP-75	0.4 (0.18)
MEDIUM R-CLIP	TC RC-MED	- (-)

* Spans greater than 40 ft require custom sleeves for larger towers