

Box Truss Light Duty Truss 12" x 12" - Guardian +

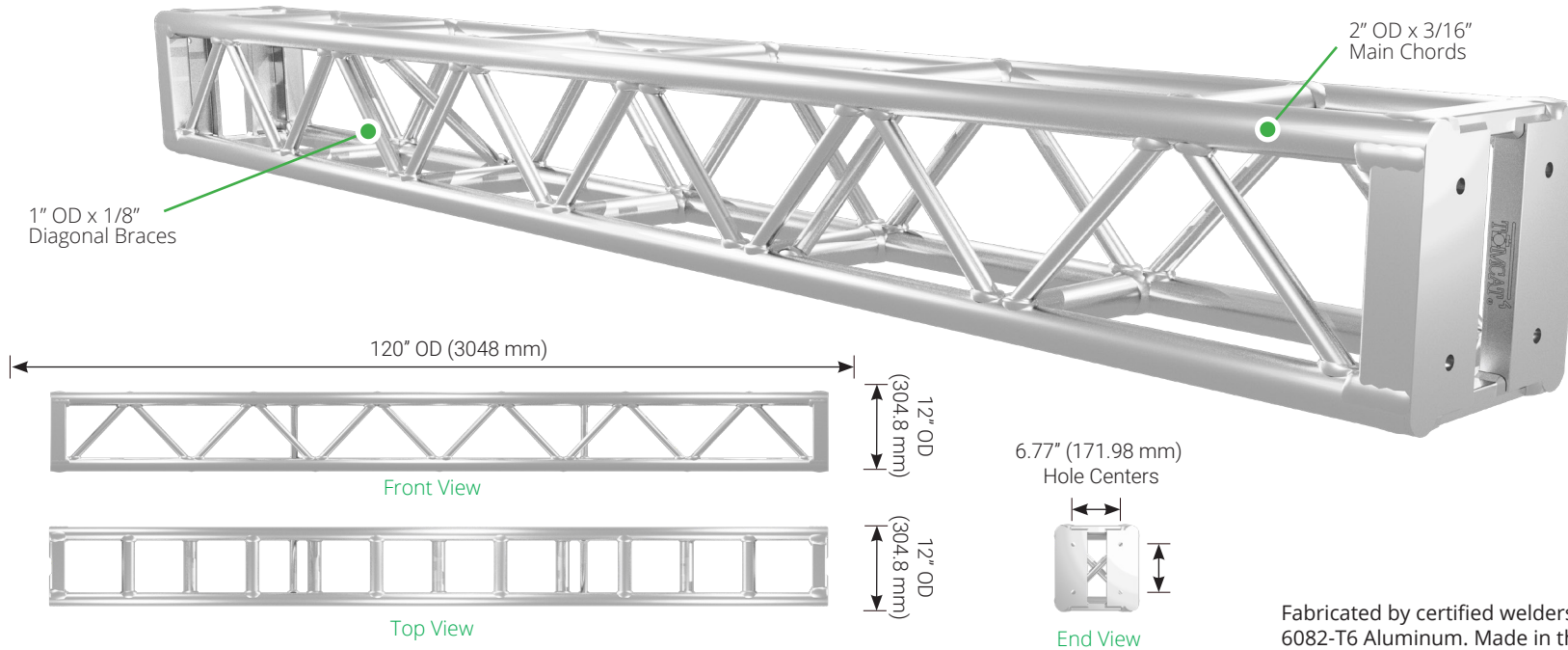

Fabricated by certified welders from 6061-T6 or 6082-T6 Aluminum. Made in the USA and Europe.

STANDARD LENGTHS

| LENGTH | ITEM CODE | WEIGHT | |
|--------|---------------|--------|-----|
| | | LBS | KGS |
| 2 ft | TC 1212-024G+ | 26 | 12 |
| 2.5 ft | TC 1212-030G+ | 30 | 14 |
| 3 ft | TC 1212-036G+ | 33 | 15 |
| 4 ft | TC 1212-048G+ | 40 | 19 |
| 5 ft | TC 1212-060G+ | 47 | 22 |
| 6 ft | TC 1212-072G+ | 54 | 25 |
| 8 ft | TC 1212-096G+ | 68 | 31 |
| 10 ft | TC 1212-120G+ | 81 | 37 |

- Four (4) connection sets are included.
- Custom truss lengths are available.
- Truss is supplied in brushed natural aluminum finish as standard with powder coated options upon request.

CORNERS

| PRODUCT | ITEM CODE | WEIGHT | |
|--------------|--------------|--------|-----|
| | | LBS | KGS |
| 2 Way Corner | TC 1212-C2G+ | 21 | 10 |
| 3 Way Corner | TC 1212-C3G+ | 25 | 12 |
| 4 Way Corner | TC 1212-C4G+ | 30 | 14 |
| 5 Way Corner | TC 1212-C5G+ | 32 | 15 |
| 6 Way Corner | TC 1212-C6G+ | 34 | 16 |

• Please specify connection orientation on 2 Way – 4 Way Corners.

TOMCAT recommends using the tru corner with Guardian +

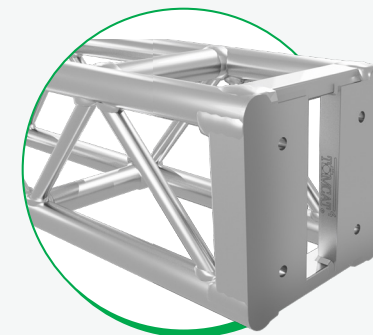
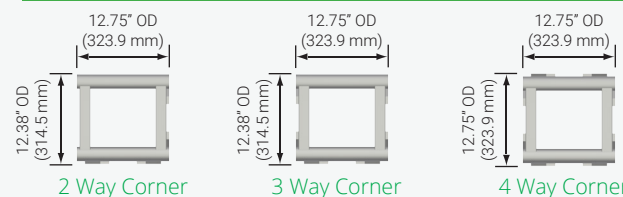

Guardian's unique connection plate extrusion provides support and protection for the ends of the chords reducing the risk of tube damage. The design also provides up to 160% more truss load capacity compared to conventional TOMCAT Light Duty 12" x 12" truss utilizing standard end plates.

Box Truss Light Duty Truss 12" x 12" - Guardian +



Maximum Allowable Loading (Deflection Limited to L/100)

| SIMPLE SPAN (DISTANCE BETWEEN SUPPORTS) | | UNIFORMLY DISTRIBUTED LOAD | | | MAXIMUM ALLOWABLE LOAD PER POINT | | | | | | | |
|--|--------|----------------------------|------------|------------|----------------------------------|------------|------------------|------------|--------------------|------------|------------------|------------|
| | | | | | CENTER POINT LOAD | | THIRD POINT LOAD | | QUARTER POINT LOAD | | FIFTH POINT LOAD | |
| | | LOAD | TOTAL LOAD | DEFLECTION | LOAD | DEFLECTION | LOAD | DEFLECTION | LOAD | DEFLECTION | LOAD | DEFLECTION |
| FEET | METERS | LBS/FT | LBS | INCHES | LBS | INCHES | LBS | INCHES | LBS | INCHES | LBS | INCHES |
| 10 | 3 | 764 | 7600 | 0.16 | 5434 | 0.18 | 3801 | 0.22 | 2534 | 0.20 | 1901 | 0.19 |
| 15 | 4.6 | 482 | 7185 | 0.51 | 3591 | 0.41 | 2693 | 0.53 | 1795 | 0.49 | 1496 | 0.51 |
| 20 | 6.1 | 269 | 5320 | 0.90 | 2659 | 0.73 | 1995 | 0.94 | 1330 | 0.87 | 1108 | 0.91 |
| 25 | 7.6 | 171 | 4175 | 1.41 | 2093 | 1.15 | 1570 | 1.46 | 1047 | 1.36 | 872 | 1.43 |
| 30 | 9.1 | 117 | 3420 | 2.04 | 1709 | 1.68 | 1282 | 2.11 | 855 | 1.97 | 712 | 2.06 |
| 35 | 10.7 | 85 | 2870 | 2.79 | 1430 | 2.31 | 1072 | 2.89 | 715 | 2.69 | 596 | 2.81 |
| 40 | 12.2 | 64 | 2440 | 3.66 | 1215 | 3.05 | 911 | 3.78 | 608 | 3.54 | 506 | 3.69 |
| 45 | 13.7 | 50 | 2070 | 4.66 | 1044 | 4.89 | 774 | 4.76 | 522 | 4.51 | 435 | 4.69 |
| 50 | 15.2 | 39 | 1600 | 5.27 | 908 | 4.89 | 589 | 5.33 | 423 | 5.32 | 332 | 5.27 |

Allowable Loading Guidelines

- The truss is designed with two faces of diagonal bracing. The truss was reviewed for load in one direction only, assumed to be parallel in orientation to the diagonal braces located on the opposite two faces of the module or span. If loads are applied in multiple axes, then the loading shall be approved by a qualified person.
- The truss was analyzed as a static simple span beam. The span lengths shown in the table should be the distance between supports, assumed to be at each end of the span. Any usage outside of this scope, cantilevers, dynamic loads, indeterminate structures, etc. shall be approved by a qualified person.
- The maximum span length shown in the table should not be exceeded without approval by a qualified person.
- All loads and supports shall be located at a panel point within the truss.
- The truss was analyzed assuming that the loads were applied at the centroid of the truss so as to not induce twisting or torsion. Unbalanced or off-center loading scenarios shall be approved by a qualified person.
- The self-weight of the truss has already been removed from the allowable loading data.
- Allowable loads based on the 2020 Aluminum Design Manual.
- The deflection shown in the table is theoretical, actual deflection measurements can vary.
- The allowable loading has been reduced to limit deflection to L/100, where L equals the simple span length. Please contact TOMCAT for L/180 and non-deflection-limited loading data.
- Simple span lengths are assumed to be constructed from the minimum number of truss modules 10ft long or less. For example, a 35ft simple span is assumed to be made from 3 x 10ft sections & 1 x 5ft section of truss.
- The allowable loading has been reduced by a factor of 0.85 for repetitive use as per ANSI E1.2-2021. Note that removing this limit could result in deflection greater than L/100.
- Please consult the appropriate TOMCAT truss user manual before use. Please contact TOMCAT should you require a copy.
- The load tables are reprinted from engineering reports developed by Clark Reder Engineering, Inc., dated September 17, 2025.

Uniformly Distributed Load Deflection Calculator (Deflection Limited to L/100)

| SIMPLE SPAN (DISTANCE BETWEEN SUPPORTS) | | TOTAL LOAD | % OF MAXIMUM UNIFORMLY DISTRIBUTED LOAD CAPACITY USED | | | | | | | | | |
|--|--------|------------|---|------------|------|------------|------|------------|------|------------|------|------------|
| | | | 0% | | 25% | | 50% | | 75% | | 100% | |
| | | | LOAD | DEFLECTION | LOAD | DEFLECTION | LOAD | DEFLECTION | LOAD | DEFLECTION | LOAD | DEFLECTION |
| FEET | METERS | LBS | LBS | INCHES | LBS | INCHES | LBS | INCHES | LBS | INCHES | LBS | INCHES |
| 10 | 3 | 7640 | 0 | 0.00 | 1910 | 0.04 | 3820 | 0.08 | 5730 | 0.12 | 7640 | 0.16 |
| 15 | 4.6 | 7230 | 0 | 0.01 | 1808 | 0.13 | 3615 | 0.26 | 5423 | 0.38 | 7230 | 0.51 |
| 20 | 6.1 | 5380 | 0 | 0.03 | 1345 | 0.24 | 2690 | 0.46 | 4035 | 0.68 | 5380 | 0.90 |
| 25 | 7.6 | 4275 | 0 | 0.06 | 1069 | 0.40 | 2137 | 0.74 | 3207 | 1.07 | 4275 | 1.41 |
| 30 | 9.1 | 3510 | 0 | 0.13 | 878 | 0.61 | 1755 | 1.08 | 2633 | 1.56 | 3510 | 2.03 |
| 35 | 10.7 | 2975 | 0 | 0.24 | 744 | 0.88 | 1488 | 1.51 | 2231 | 2.15 | 2975 | 2.78 |
| 40 | 12.2 | 2560 | 0 | 0.41 | 640 | 1.22 | 1280 | 2.02 | 1920 | 2.83 | 2560 | 3.63 |
| 45 | 13.7 | 2250 | 0 | 0.65 | 563 | 1.64 | 1125 | 2.63 | 1688 | 3.62 | 2250 | 4.61 |
| 50 | 15.2 | 1950 | 0 | 0.99 | 488 | 2.17 | 975 | 3.35 | 1463 | 4.53 | 1950 | 5.71 |